

MONROE TOWNSHIP, MIDDLESEX COUNTY

ORDINANCE NO.: O-4-2020-006

ORDINANCE OF THE MONROE TOWNSHIP COUNCIL
AUTHORIZING THE ACCEPTANCE OF A TRAFFIC CONTROL SIGNAL LOCATED
AT THE INTERSECTION OF PROSPECT PLAINS ROAD (CR 614) AND
PERRINEVILLE ROAD (CR 625) IN THE TOWNSHIP OF MONROE, COUNTY OF
MIDDLESEX, STATE OF NEW JERSEY

BE IT ORDAINED by the Township Council of the Township of Monroe, in the County of Middlesex, State of New Jersey as follows:

SECTION 1. The intersection of Prospect Plains Road (CR 614) and Perrineville Road (CR 625) shall be controlled by a Traffic Control Signal in accordance with the As-Built Traffic Signal Plan dated December 12, 2019, prepared by Amertech Engineering, Inc., and Traffic Signal Timing Directive, revised April 2019, prepared by CME Associates.

SECTION 2. The Traffic Control Signal shall be in accordance with the provisions of the Manual on Uniform Traffic Control Devices, Title 39 of the Revised Statutes and the New Jersey Administrative Code, and ADA Standards. Said Traffic Control Signal shall be operated in conformance with the designated Plan.

SECTION 3. All prior Ordinances and/or Resolutions or portions thereof of the Township of Monroe inconsistent with the provisions of this Ordinance shall be and the same are hereby repealed.

SECTION 4. That this Ordinance shall become effective upon adoption and publication as required by law.

SECTION 5. That if any clause, section, paragraph, subdivision, or provision of this Ordinance declared invalid by a Court of competent jurisdiction, such provision shall be deemed a separate distinct and independent provision and shall not affect the validity of the remaining portion hereof.

SECTION 6. When the Ordinance is finally adopted, the Township Clerk will send a certified copy of the Ordinance to Ronald Sendner, PE, Acting Middlesex County Engineer, P.O. Box 871, 75 Bayard Street, 5th Floor, New Brunswick, N.J. 08901, for submission to the Middlesex County Board of Chosen Freeholders for a consenting resolution.

SECTION 7. Any section of any other Township rule, regulation, policy, ordinance or requirements that conflicts with any part of this Ordinance is repealed to the extent of the conflict.

SECTION 8. If any chapter, section, subchapter or paragraph of this Ordinance be declared unconstitutional, invalid, or inoperative, in whole or in part, by a court of competent jurisdiction, such chapter, section, subchapter or paragraph shall to the extent that is not held unconstitutional, invalid, or inoperative remain in full effect and shall not affect the remainder of this Ordinance.

SECTION 9. This Ordinance shall take effect upon final passage and publication as provided by law.

SO ORDAINED, as aforesaid.

MIRIAM COHEN, Council President

RECORDED VOTE – INTRODUCTION – April 6, 2020						
COUNCIL	MOTION	SECOND	AYE	NAY	ABSTAIN	ABSENT
Councilman Baskin	X		X			
Councilman Dalina			X			
Councilman Dipierro			X			
Council V. President Schneider		X	X			
Council President Cohen			X			

NOTICE

Notice is hereby given that the foregoing Ordinances was introduced and passed on first reading at the regular meeting of the Monroe Township Council held telephonically on April 6, 2020 and will be further considered for final passage after a Public Hearing during the council meeting to be held on May 4, 2020 at 6:30 p.m. in the Monroe Twp. Municipal Building, One Municipal Plaza, Monroe Twp., N.J. 08831 or held telephonically. Due to the current circumstances this has yet to be determined. At said time and place, all persons will be granted the opportunity to be heard concerning this Ordinance prior to its consideration for adoption by Council.



PATRICIA REID, Township Clerk

RECORDED VOTE – SECOND READING & FINAL ADOPTION– May 4, 2020						
COUNCIL	MOTION	SECOND	AYE	NAY	ABSTAIN	ABSENT
Councilman Baskin	X		X			
Councilman Dalina			X			
Councilman Dipierro		X	X			
Council V. President Schneider			X			
Council President Cohen			X			

ORDINANCE NO.: O-4-2020-006

**ORDINANCE OF THE MONROE TOWNSHIP COUNCIL
AUTHORIZING THE ACCEPTANCE OF A TRAFFIC CONTROL SIGNAL LOCATED
AT THE INTERSECTION OF PROSPECT PLAINS ROAD (CR 614) AND
PERRINEVILLE ROAD (CR 625) IN THE TOWNSHIP OF MONROE, COUNTY OF
MIDDLESEX, STATE OF NEW JERSEY**

MAYORAL APPROVAL

By virtue of the Optional Municipal Charter Law of 1950 and Chapter 3, Section 19 of the Code of the Township of Monroe, my approval of this Ordinance is effected by the affixing of my signature hereto.



GERALD W. TAMBURRO, Mayor

Date signed: 5/5/2020



Township of Monroe

County of Middlesex

MARK J. RASIMOWICZ, PE, PP, CME, CPWM
Township Engineer

DEPARTMENT OF ENGINEERING
c/o Center State Engineering
481 Spotswood-Englishtown Road
Monroe Township, New Jersey 08831
Phone 732.605.9440
Fax 732.605.9444

March 12, 2020

Township of Monroe
Ms. Patricia Reid, Township Clerk
1 Municipal Plaza
Monroe Township, NJ 08831

**Re: Prospect Plains Road (CR614) and
Perrineville Road (CR625) Intersection Improvements
Monroe Township, New Jersey
CSE No. 20-001-04
Acceptance of Traffic Signal**

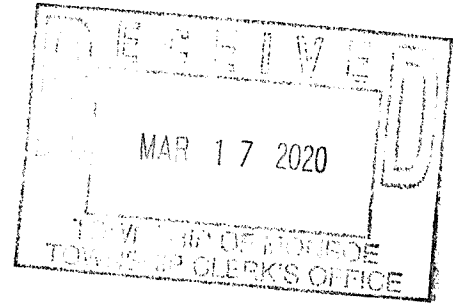

Dear Ms. Reid:

Per the attached, CME Associates and this office have conducted final inspection of the captioned intersection and find all improvements to be acceptable. In order for Middlesex County to accept the signal formally, the Township's acceptance must be done by ordinance.

Enclosed you will find a draft ordinance of the Township accepting the noted intersection improvements. A copy has also been emailed to you for your use.

Two copies of the Monroe Township's acceptance ordinance are required to be submitted to Ronald Sendner, PE, Middlesex County Engineer, PO Box 871, 333 Townsend Street, New Brunswick, NJ 08903.

Kindly schedule this on the next available Council agenda. If you require anything further, please do not hesitate to contact this office.

Very truly yours,

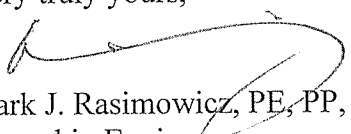
Mark J. Rasimowicz, PE, PP, CME
Township Engineer

MJR/dh

C: Alan Weinberg, Business Administrator

JOHN H. ALLGAIR, PE, PP, LS (1983-2001)
DAVID J. SAMUEL, PE, PP, CME
JOHN J. STEFANI, PE, LS, PP, CME
JAY B. CORNELL, PE, PP, CME
MICHAEL J. McCLELLAND, PE, PP, CME
GREGORY R. VALES, PE, PP, CME



TIM W. GILLEN, PE, PP, CME (1991-2019)
BRUCE M. KOCH, PE, PP, CME
LOUIS J. PLOSKONKA, PE, CME
TREVOR J. TAYLOR, PE, PP, CME
BEHRAM TURAN, PE, LSRP
LAURA J. NEUMANN, PE, PP
DOUGLAS ROHMEYER, PE, CFM, CME
ROBERT J. RUSSO, PE, PP, CME
JOHN J. HESS, PE, PP, CME

January 13, 2020

SENT VIA MAIL AND EMAIL [MRasimowicz@CenterStateEngineering.com]

Center State Engineering
481 Spotswood-Englishtown Road
Monroe Township, NJ 08831-3223

Attn: Mark J. Rasimowicz, PE, PP, CME, CPWM
Monroe Township Engineer

**Re: *Modifications/Upgrades to
Prospect Plains Road and Perrineville Road
Monroe Township
Middlesex County, New Jersey
County Project No.: MON010
Our File No.: PCT00091.02***

Dear Mr. Rasimowicz:

Please be advised that the construction phase of the above referenced project is complete. As you may recall, a final walkthrough meeting with Middlesex County and Monroe Township was held on Tuesday, August 13, 2019 to perform a final inspection, and to discuss scheduling and close-out procedures for the project. The results of the inspection found that the project is in conformance with the approved plans, specifications and N.J. DOT standards, and that the Contractor, Lucas Construction Group, Inc. has satisfactorily completed the project with only a couple administrative and corrective work items remaining to be completed. Please note that the Contractor completed the corrective work items on Tuesday, October 1, 2019, and as of Monday, October 28, 2019 Middlesex County re-inspected the intersection and found it to be acceptable for responsibility of maintenance. Therefore, October 28, 2019 is considered the date for the End of Construction.

As you may be aware, Municipalities shall adopt an Ordinance accepting the Traffic Control Signal installation as part of the above referenced project. After adoption of the Ordinance, Middlesex County will then adopt a Consenting Resolution approving said Ordinance. This must be accomplished in order for the County to approve the Traffic Control Signal installation.

Pursuant to the above, enclosed please find the following information regarding the above referenced project:



Mark J. Rasimowicz, PE, PP, CME, CPWM
Modifications/Upgrades to
Prospect Plains Road and Perrineville Road
Monroe Township
Middlesex County, New Jersey
January 13, 2020
Page 2

1. One (1) Sample Township Ordinance for Prospect Plains Road (Co. Rt. 614) and Perrineville Road (Co. Rt. 625);
2. One (1) copy of the Traffic Signal System Certification, as prepared Lee D. Klein, P.E., PTOE, of Klein Traffic Consulting, LLC;
3. One (1) copy of the Traffic Signal Timing Directive, Sheets 1-5 of 5, dated March 2016, Revised April 2019, as prepared by our office;
4. One (1) copy of the As-Built Traffic Signal Plan, dated December 12, 2019, as prepared by Juan J. Rodriguez, P.L.S., of Amertech Engineering, Inc.; and
5. One (1) copy of the Preliminary As-Built Electrical Plan, dated December 2019, as prepared by our office.

At your earliest convenience, kindly have an Ordinance established for the Prospect Plains Road (Co. Rt. 614) and Perrineville Road (Co. Rt. 625) intersection and provide our office with a certified copy of same so we may proceed with the approval process.

Should you have any questions regarding this matter, please do not hesitate to contact this office.

Very truly yours,

CME Associates

R. Eric Robinson, PE, CME
Project Leader

RER/rr

Enclosures

cc: Ed Kuchie, Senior Engineer, Middlesex County's Office of Engineering SENT VIA EMAIL [engineering@co.middlesex.nj.us]
Steve Amos, Lucas Construction Group, Inc. SENT VIA EMAIL [SteveAmos@lucascg.com]
Ambrose J. Cooper IV, Lucas Construction Group, Inc. SENT VIA EMAIL [AmbroseCooper@lucascg.com]

KLEIN

TRAFFIC CONSULTING, LLC

156 Walker Road
West Orange, NJ 07052
973-985-3464
leekleintraffic@gmail.com

TRAFFIC SIGNAL SYSTEM CERTIFICATION

I hereby certify that the installation of a traffic signal at the intersection of Prospect Plains Road (Middlesex County Route 614) with Perrineville Road (Middlesex County Route 625) in the Township of Monroe, Middlesex County, New Jersey, Middlesex County Contract Number TR-1235 has been inspected on June 7, 2019 and June 19, 2019 and completed in accordance with the As-Built Traffic Signal Plan dated 12/12/19, prepared by Amertech Engineering, and timing schedule dated 4/17/2018, revised April 2019. I hereby certify that the installation is in accordance set forth in the 2009 "Manual on Uniform Traffic Control Devices (MUTCD) for Streets and Highways".



Lee D. Klein, P.E., PTOE
NJPE 24GE03710400
PTOE Certification 1627

WITHOUT PEDESTRIAN ACTUATION

SIGNAL	PERRINEVILLE ROAD (RT. 625)		PROSPECT PLAINS ROAD (RT. 614)				PEDESTRIAN SIGNALS				SIGNAL TIMING		
	S.B.		W.B.		E.B.		26-29		32-35		6 A.M. TO 10 A.M.		
	N.B.	S.B.	6,7,8	9,10,11	1,2,3	4,5	30,31	36,37	DW	DW	MIN.	MAX.	
PHASE 1	12,13,14	15,16,17,25	18,19,20	21,22,23,24	R	R	R	R	R	DW	DW	5	9
CHANGE	←	←	←	←	R	R	R	R	R	DW	DW	3	3
CLEARANCE	←	←	←	←	R	R	R	R	R	DW	DW	2	2
PHASE 2	←	←	←	←	R	R	R	R	R	DW	DW	8	23
CHANGE	←	←	←	←	R	R	R	R	R	DW	DW	4	4
CLEARANCE	←	←	←	←	R	R	R	R	R	DW	DW	3	3
PHASE 3	←	←	←	←	R	R	R	R	R	DW	DW	5	10
CHANGE	←	←	←	←	R	R	R	R	R	DW	DW	3	3
CLEARANCE	←	←	←	←	R	R	R	R	R	DW	DW	-	-
PHASE 4	←	←	←	←	R	R	R	R	R	DW	DW	6	13
CHANGE	←	←	←	←	R	R	R	R	R	DW	DW	5	5
CLEARANCE	←	←	←	←	R	R	R	R	R	DW	DW	2	2
EMERGENCY FLASH	←	←	←	←	R	R	R	R	R	NOT ILLUMINATED	NOT ILLUMINATED	50 TO 60 FLASHES PER MINUTE	50 TO 60 FLASHES PER MINUTE

WITH PEDESTRIAN ACTUATION

SIGNAL	PERRINEVILLE ROAD (RT. 625)		PROSPECT PLAINS ROAD (RT. 614)				PEDESTRIAN SIGNALS				SIGNAL TIMING		
	S.B.		W.B.		E.B.		26-29		32-35		6 A.M. TO 10 A.M.		
	N.B.	S.B.	6,7,8	9,10,11	1,2,3	4,5	30,31	36,37	DW	DW	MIN.	MAX.	
PHASE 1	12,13,14	15,16,17,25	18,19,20	21,22,23,24	R	R	R	R	R	DW	DW	5	9
PED. CLEAR.	←	←	←	←	R	R	R	R	R	DW	DW	-	-
VEH. EXT.	←	←	←	←	R	R	R	R	R	DW	DW	-	-
CHANGE	←	←	←	←	R	R	R	R	R	DW	DW	3	3
CLEARANCE	←	←	←	←	R	R	R	R	R	DW	DW	2	2
PHASE 2	←	←	←	←	R	R	R	R	R	DW	DW	20	20
PED. CLEAR.	←	←	←	←	R	R	R	R	R	DW	DW	20	20
VEH. EXT.	←	←	←	←	R	R	R	R	R	DW	DW	-	-
CHANGE	←	←	←	←	R	R	R	R	R	DW	DW	4	4
CLEARANCE	←	←	←	←	R	R	R	R	R	DW	DW	3	3
PHASE 3	←	←	←	←	R	R	R	R	R	DW	DW	5	10
PED. CLEAR.	←	←	←	←	R	R	R	R	R	DW	DW	-	-
VEH. EXT.	←	←	←	←	R	R	R	R	R	DW	DW	-	-
CHANGE	←	←	←	←	R	R	R	R	R	DW	DW	3	3
CLEARANCE	←	←	←	←	R	R	R	R	R	DW	DW	18	18
PHASE 4	←	←	←	←	R	R	R	R	R	DW	DW	18	18
PED. CLEAR.	←	←	←	←	R	R	R	R	R	DW	DW	-	-
VEH. EXT.	←	←	←	←	R	R	R	R	R	DW	DW	-	-
CHANGE	←	←	←	←	R	R	R	R	R	DW	DW	5	5
CLEARANCE	←	←	←	←	R	R	R	R	R	DW	DW	2	2
EMERGENCY FLASH	←	←	←	←	R	R	R	R	R	NOT ILLUMINATED	NOT ILLUMINATED	50 TO 60 FLASHES PER MINUTE	50 TO 60 FLASHES PER MINUTE

46 SEC. TO 117 SEC. MAX. VARIABLE CYCLE

SIGNAL TIMING

NOTES:
 1. PHASES NOT ACTUATED SHALL BE CAPABLE OF BEING SKIPPED.

2. EQUIPMENT FOR MANUAL CONTROL OF THE INTERSECTION SHALL BE PROVIDED, BUT NOT CONNECTED.
3. MEMORY OFF, VEHICLE EXTENSION SET AT 2 SECONDS.
4. PHASE 2, WITHOUT PEDESTRIAN ACTUATION, TO BE ON SOFT RECALL AT ALL TIMES.
5. PHASES 1 & 3 PROVIDE FOR PROTECTED LEAD LEFT TURNS.
6. PHASE 2 MUST FOLLOW PHASE 1.
7. PHASE 4 MUST FOLLOW PHASE 3.
8. CONTROLLER TO BE EQUIPPED WITH EMERGENCY VEHICLE PREEMPTION.
9. 3 SECOND DELAY FOR LEFT TURN SLOT DETECTION.
10. 5 SECOND DELAY FOR PROSPECT PLAINS ROAD DETECTION.
11. THE LEFT TURN SLOTS ARE TO OPERATE SIMULTANEOUSLY AND INDEPENDENTLY. IN THE ABSENCE OF VEHICLE DEMAND THE OPPOSING VEHICLE AND PEDESTRIAN MOVEMENTS ARE TO COMMENCE FOLLOWING THE NECESSARY CLEARANCES.

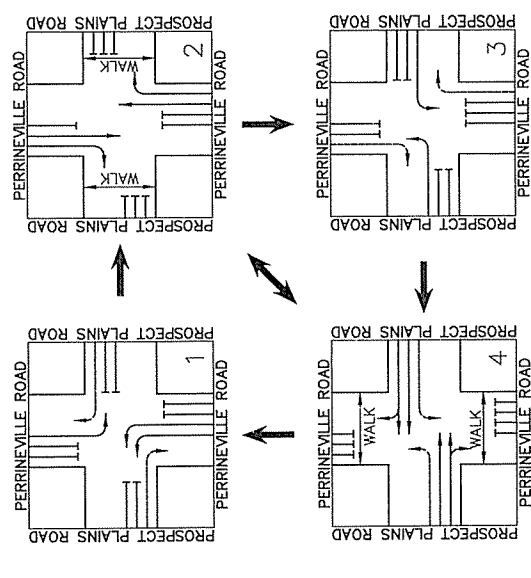

SIGNAL PHASING

TOWNSHIP OF MONROE
 MIDDLESEX COUNTY, NEW JERSEY

MODIFICATIONS/UPGRADES TO PROSPECT
 PLAINS ROAD AND PERRINEVILLE ROAD

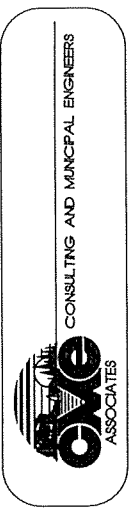

SIGNAL	PERRINEVILLE ROAD (RT. 625)				PROSPECT PLAINS ROAD (RT. 614)				PEDESTRIAN SIGNALS				SIGNAL TIMING
	N.B.		S.B.		W.B.		E.B.		30,31	36,37	26-29	32-35	
PHASE	12,13,14	15,16,17,25	18,19,20	21,22,23,24	6,7,8	9,10,11	1,2,3	4,5	DW	DW	DW	DW	6 (MIN)**
1	← G	R	← G	R	R	R	R	R	DW	DW	DW	DW	
UPON ACTUATION													
CHANGE	← G	R	← Y	R	R	R	R	R	DW	DW	DW	DW	3
CLEARANCE	← G	R	← R	R	R	R	R	R	DW	DW	DW	DW	2
EMERGENCY VEHICLE	← G	G	← R	R	R	R	R	R	DW	DW	DW	DW	10 (MIN) AND HOLD UNTIL RELEASED****
CHANGE	← Y	Y	← R	R	R	R	R	R	DW	DW	DW	DW	4
CLEARANCE	← R	R	← R	R	R	R	R	R	DW	DW	DW	DW	3
2	← R	G	← R	G	R	R	R	R	DW	DW	DW	DW	6 (MIN)*****
RESUME NORMAL OPERATION													

SIGNAL	PERRINEVILLE ROAD (RT. 625)				PROSPECT PLAINS ROAD (RT. 614)				PEDESTRIAN SIGNALS				SIGNAL TIMING
	N.B.		S.B.		W.B.		E.B.		30,31	36,37	26-29	32-35	
PHASE	12,13,14	15,16,17,25	18,19,20	21,22,23,24	6,7,8	9,10,11	1,2,3	4,5	W*	W*	DW	DW	6 (MIN)**
2	← R	G	← R	G	R	R	R	R	DW	DW	DW	DW	
UPON ACTUATION													
PED. CLEAR	← R	G	← R	G	R	R	R	R	FDW	FDW	DW	DW	20***
CHANGE	← R	G	← R	Y	R	R	R	R	DW	DW	DW	DW	4
CLEARANCE	← R	G	← R	R	R	R	R	R	DW	DW	DW	DW	3
EMERGENCY VEHICLE	← G	G	← R	R	R	R	R	R	DW	DW	DW	DW	10 (MIN) AND HOLD UNTIL RELEASED****
CHANGE	← Y	Y	← R	R	R	R	R	R	DW	DW	DW	DW	4
CLEARANCE	← R	R	← R	R	R	R	R	R	DW	DW	DW	DW	3
2	← R	G	← R	G	R	R	R	R	DW	DW	DW	DW	6 (MIN)*****
RESUME NORMAL OPERATION													

SIGNAL	PERRINEVILLE ROAD (RT. 625)				PROSPECT PLAINS ROAD (RT. 614)				PEDESTRIAN SIGNALS				SIGNAL TIMING
	N.B.		S.B.		W.B.		E.B.		30,31	36,37	26-29	32-35	
PHASE	12,13,14	15,16,17,25	18,19,20	21,22,23,24	6,7,8	9,10,11	1,2,3	4,5	DW	DW	DW	DW	6 (MIN)**
3	← R	R	← R	R	← G/R	R	← G/R	R	DW	DW	DW	DW	
UPON ACTUATION													
CHANGE	← R	R	← R	R	← Y/R	R	← Y/R	R	DW	DW	DW	DW	3
CLEARANCE	← R	R	← R	R	R	R	R	R	DW	DW	DW	DW	2
EMERGENCY VEHICLE	← G	G	← R	R	R	R	R	R	DW	DW	DW	DW	10 (MIN) AND HOLD UNTIL RELEASED****
CHANGE	← Y	Y	← R	R	R	R	R	R	DW	DW	DW	DW	4
CLEARANCE	← R	R	← R	R	R	R	R	R	DW	DW	DW	DW	3
2	← R	G	← R	G	R	R	R	R	DW	DW	DW	DW	6 (MIN)*****
RESUME NORMAL OPERATION													

SIGNAL	PERRINEVILLE ROAD (RT. 625)				PROSPECT PLAINS ROAD (RT. 614)				PEDESTRIAN SIGNALS				SIGNAL TIMING
	N.B.		S.B.		W.B.		E.B.		30,31	36,37	26-29	32-35	
PHASE	12,13,14	15,16,17,25	18,19,20	21,22,23,24	6,7,8	9,10,11	1,2,3	4,5	DW	DW	W*	W*	6 (MIN)**
4	← R	R	← R	R	G	G	G	G	DW	DW	DW	DW	
UPON ACTUATION													
PED. CLEAR	← R	R	← R	R	G	G	G	G	DW	DW	FDW	FDW	18***
CHANGE	← R	R	← R	R	Y	Y	Y	Y	DW	DW	DW	DW	5
CLEARANCE	← R	R	← R	R	R	R	R	R	DW	DW	DW	DW	2
EMERGENCY VEHICLE	← G	G	← R	R	R	R	R	R	DW	DW	DW	DW	10 (MIN) AND HOLD UNTIL RELEASED****
CHANGE	← Y	Y	← R	R	R	R	R	R	DW	DW	DW	DW	4
CLEARANCE	← R	R	← R	R	R	R	R	R	DW	DW	DW	DW	3
2	← R	G	← R	G	R	R	R	R	DW	DW	DW	DW	6 (MIN)*****
RESUME NORMAL OPERATION													

EMERGENCY VEHICLE PREEMPTION

NOTES:

- * "DW" SHALL BE DISPLAYED IF PEDESTRIAN ACTUATION DOES NOT OCCUR.
- ** MOVEMENT BEING PREEMPTED SHALL BE GUARANTEED A MINIMUM OF 6 SECONDS OF GREEN TIME.
- *** IF PEDESTRIAN ACTUATION DOES NOT OCCUR, THIS PHASE SHALL BE SKIPPED.
- ACTUATION OF PREEMPTION SHALL NOT INTERRUPT ANY YELLOW CHANGE, ALL RED CLEARANCE OR FLASHING DON'T WALK PEDESTRIAN CLEARANCE TIMES. THE RESPECTIVE YELLOW CHANGE AND ALL RED CLEARANCE INTERVALS SHALL NOT BE SKIPPED PRIOR TO RESUMING NORMAL OPERATIONS.
- **** EMERGENCY VEHICLE SHALL BE GUARANTEED A MINIMUM OF 10 SECONDS GREEN TIME AND SHALL HOLD UNTIL RELEASED.
- ***** PHASE 2 SHALL BE GUARANTEED A MINIMUM OF 6 SECONDS GREEN TIME.

TOWNSHIP OF MONROE
MIDDLESEX COUNTY, NEW JERSEY
MODIFICATIONS/UPGRADES TO PROSPECT PLAINS
ROAD AND PERRINEVILLE ROAD

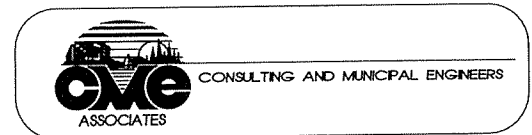

SIGNAL	PERRINEVILLE ROAD (RT. 625)						PROSPECT PLAINS ROAD (RT. 614)				PEDESTRIAN SIGNALS				SIGNAL TIMING
	N.B.			S.B.			W.B.		E.B.						
	12,13,14	15,16,17,22	18,19,20	21,22,23,24	6,7,8	9,10,11	1,2,3	4,5	30,31	36,37	26-29	32-35			
PHASE 1	← G	← R	← G	← R	← R	← R	← R	← R	← R	DW	DW	DW	DW	6 (MIN)**	
UPON ACTUATION															
CHANGE	← Y	← R	← G	← R	← R	← R	← R	← R	← R	DW	DW	DW	DW	3	
CLEARANCE	← R	← R	← G	← R	← R	← R	← R	← R	← R	DW	DW	DW	DW	2	
EMERGENCY VEHICLE	← R	← R	← G	← G	← R	← R	← R	← R	← R	DW	DW	DW	DW	10 (MIN) AND HOLD UNTIL RELEASED****	
CHANGE	← Y	← R	← Y	← Y	← R	← R	← R	← R	← R	DW	DW	DW	DW	4	
CLEARANCE	← R	← R	← R	← R	← R	← R	← R	← R	← R	DW	DW	DW	DW	3	
2	← R	← G	← R	← G	← R	← R	← R	← R	← R	DW	DW	DW	DW	6 (MIN)*****	
RESUME NORMAL OPERATION															

SIGNAL	PERRINEVILLE ROAD (RT. 625)						PROSPECT PLAINS ROAD (RT. 614)				PEDESTRIAN SIGNALS				SIGNAL TIMING
	N.B.			S.B.			W.B.		E.B.						
	12,13,14	15,16,17,22	18,19,20	21,22,23,24	6,7,8	9,10,11	1,2,3	4,5	30,31	36,37	26-29	32-35			
PHASE 2	← R	← G	← R	← G	← R	← R	← R	← R	← R	W*	W*	DW	DW	6 (MIN)**	
UPON ACTUATION															
PED. CLEAR	← R	← G	← R	← G	← R	← R	← R	← R	← R	FDW	FDW	DW	DW	20***	
CHANGE	← R	← Y	← R	← G	← R	← R	← R	← R	← R	DW	DW	DW	DW	4	
CLEARANCE	← R	← R	← R	← G	← R	← R	← R	← R	← R	DW	DW	DW	DW	3	
EMERGENCY VEHICLE	← R	← R	← G	← G	← R	← R	← R	← R	← R	DW	DW	DW	DW	10 (MIN) AND HOLD UNTIL RELEASED****	
CHANGE	← R	← R	← Y	← Y	← R	← R	← R	← R	← R	DW	DW	DW	DW	4	
CLEARANCE	← R	← R	← R	← R	← R	← R	← R	← R	← R	DW	DW	DW	DW	3	
2	← R	← G	← R	← G	← R	← R	← R	← R	← R	DW	DW	DW	DW	6 (MIN)*****	
RESUME NORMAL OPERATION															

SIGNAL	PERRINEVILLE ROAD (RT. 625)						PROSPECT PLAINS ROAD (RT. 614)				PEDESTRIAN SIGNALS				SIGNAL TIMING
	N.B.			S.B.			W.B.		E.B.						
	12,13,14	15,16,17,22	18,19,20	21,22,23,24	6,7,8	9,10,11	1,2,3	4,5	30,31	36,37	26-29	32-35			
PHASE 3	← R	← R	← R	← R	← G/R	← R	← G/R	← R	← R	DW	DW	DW	DW	6 (MIN)**	
UPON ACTUATION															
CHANGE	← R	← R	← R	← R	← Y/R	← R	← Y/R	← R	← R	DW	DW	DW	DW	3	
CLEARANCE	← R	← R	← R	← R	← R	← R	← R	← R	← R	DW	DW	DW	DW	2	
EMERGENCY VEHICLE	← R	← R	← G	← G	← R	← R	← R	← R	← R	DW	DW	DW	DW	10 (MIN) AND HOLD UNTIL RELEASED****	
CHANGE	← R	← R	← Y	← Y	← R	← R	← R	← R	← R	DW	DW	DW	DW	4	
CLEARANCE	← R	← R	← R	← R	← R	← R	← R	← R	← R	DW	DW	DW	DW	3	
2	← R	← G	← R	← G	← R	← R	← R	← R	← R	DW	DW	DW	DW	6 (MIN)*****	
RESUME NORMAL OPERATION															

SIGNAL	PERRINEVILLE ROAD (RT. 625)						PROSPECT PLAINS ROAD (RT. 614)				PEDESTRIAN SIGNALS				SIGNAL TIMING
	N.B.			S.B.			W.B.		E.B.						
	12,13,14	15,16,17,22	18,19,20	21,22,23,24	6,7,8	9,10,11	1,2,3	4,5	30,31	36,37	26-29	32-35			
PHASE 4	← R	← R	← R	← R	← G	← G	← G	← G	← G	DW	DW	W*	W*	6 (MIN)**	
UPON ACTUATION															
PED. CLEAR	← R	← R	← R	← R	← G	← G	← G	← G	← G	DW	DW	FDW	FDW	18***	
CHANGE	← R	← R	← R	← R	← Y	← Y	← Y	← Y	← Y	DW	DW	DW	DW	5	
CLEARANCE	← R	← R	← R	← R	← R	← R	← R	← R	← R	DW	DW	DW	DW	2	
EMERGENCY VEHICLE	← R	← R	← G	← G	← R	← R	← R	← R	← R	DW	DW	DW	DW	10 (MIN) AND HOLD UNTIL RELEASED****	
CHANGE	← R	← R	← Y	← Y	← R	← R	← R	← R	← R	DW	DW	DW	DW	4	
CLEARANCE	← R	← R	← R	← R	← R	← R	← R	← R	← R	DW	DW	DW	DW	3	
2	← R	← G	← R	← G	← R	← R	← R	← R	← R	DW	DW	DW	DW	6 (MIN)*****	
RESUME NORMAL OPERATION															

EMERGENCY VEHICLE PREEMPTION

NOTES:

- * "DW" SHALL BE DISPLAYED IF PEDESTRIAN ACTUATION DOES NOT OCCUR.
 - ** MOVEMENT BEING PREEMPTED SHALL BE GUARANTEED A MINIMUM OF 6 SECONDS OF GREEN TIME.
 - *** IF PEDESTRIAN ACTUATION DOES NOT OCCUR, THIS PHASE SHALL BE SKIPPED.
- ACTUATION OF PREEMPTION SHALL NOT INTERRUPT ANY YELLOW CHANGE, ALL RED CLEARANCE OR FLASHING DON'T WALK PEDESTRIAN CLEARANCE TIMES. THE RESPECTIVE YELLOW CHANGE AND ALL RED CLEARANCE INTERVALS SHALL NOT BE SKIPPED PRIOR TO RESUMING NORMAL OPERATIONS.
- **** EMERGENCY VEHICLE SHALL BE GUARANTEED A MINIMUM OF 10 SECONDS GREEN TIME AND SHALL HOLD UNTIL RELEASED.
 - ***** PHASE 2 SHALL BE GUARANTEED A MINIMUM OF 6 SECONDS GREEN TIME.

TOWNSHIP OF MONROE
MIDDLESEX COUNTY, NEW JERSEY
MODIFICATIONS/UPGRADES TO PROSPECT PLAINS
ROAD AND PERRINEVILLE ROAD

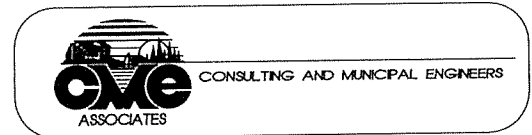

SIGNAL	PERRINEVILLE ROAD (RT. 625)						PROSPECT PLAINS ROAD (RT. 614)						PEDESTRIAN SIGNALS				SIGNAL TIMING
	N.B.			S.B.			W.B.			E.B.			30,31	36,37	26-29	32-35	
PHASE	12,13,14	15,16,17,22	18,19,20	21,22,23,24	6,7,8	9,10,11	1,2,3	4,5	30,31	36,37	26-29	32-35					6 (MIN)**
1	← G	R	← G	R	R	R	R	R	DW	DW	DW	DW					
UPON ACTUATION																	
CHANGE	← Y	R	← Y	R	R	R	R	R	DW	DW	DW	DW					3
CLEARANCE	← R	R	← R	R	R	R	R	R	DW	DW	DW	DW					2
EMERGENCY VEHICLE	← R	R	← R	R	← G/G	G	R	R	DW	DW	DW	DW					10 (MIN) AND HOLD UNTIL RELEASED****
CHANGE	← R	R	← R	R	← Y/Y	Y	R	R	DW	DW	DW	DW					5
CLEARANCE	← R	R	← R	R	← R	R	R	R	DW	DW	DW	DW					2
2	← R	G	← R	G	R	R	R	R	DW	DW	DW	DW					6 (MIN)*****
RESUME NORMAL OPERATION																	

SIGNAL	PERRINEVILLE ROAD (RT. 625)						PROSPECT PLAINS ROAD (RT. 614)						PEDESTRIAN SIGNALS				SIGNAL TIMING
	N.B.			S.B.			W.B.			E.B.			30,31	36,37	26-29	32-35	
PHASE	12,13,14	15,16,17,22	18,19,20	21,22,23,24	6,7,8	9,10,11	1,2,3	4,5	30,31	36,37	26-29	32-35					6 (MIN)**
2	← R	G	← R	G	R	R	R	R	W*	W*	DW	DW					
UPON ACTUATION																	
PED. CLEAR	← R	G	← R	G	R	R	R	R	FDW	FDW	DW	DW					20***
CHANGE	← R	Y	← R	Y	R	R	R	R	DW	DW	DW	DW					4
CLEARANCE	← R	R	← R	R	R	R	R	R	DW	DW	DW	DW					3
EMERGENCY VEHICLE	← R	R	← R	R	← G/G	G	R	R	DW	DW	DW	DW					10 (MIN) AND HOLD UNTIL RELEASED****
CHANGE	← R	R	← R	R	← Y/Y	Y	R	R	DW	DW	DW	DW					5
CLEARANCE	← R	R	← R	R	← R	R	R	R	DW	DW	DW	DW					2
2	← R	G	← R	G	R	R	R	R	DW	DW	DW	DW					6 (MIN)*****
RESUME NORMAL OPERATION																	

SIGNAL	PERRINEVILLE ROAD (RT. 625)						PROSPECT PLAINS ROAD (RT. 614)						PEDESTRIAN SIGNALS				SIGNAL TIMING
	N.B.			S.B.			W.B.			E.B.			30,31	36,37	26-29	32-35	
PHASE	12,13,14	15,16,17,22	18,19,20	21,22,23,24	6,7,8	9,10,11	1,2,3	4,5	30,31	36,37	26-29	32-35					6 (MIN)**
3	← R	R	← R	R	← G/R	R	← G/R	R	DW	DW	DW	DW					
UPON ACTUATION																	
CHANGE	← R	R	← R	R	← G/R	R	← Y/R	R	DW	DW	DW	DW					3
CLEARANCE	← R	R	← R	R	← G/R	R	R	R	DW	DW	DW	DW					2
EMERGENCY VEHICLE	← R	R	← R	R	← G/G	G	R	R	DW	DW	DW	DW					10 (MIN) AND HOLD UNTIL RELEASED****
CHANGE	← R	R	← R	R	← Y/Y	Y	R	R	DW	DW	DW	DW					5
CLEARANCE	← R	R	← R	R	← R	R	R	R	DW	DW	DW	DW					2
2	← R	G	← R	G	R	R	R	R	DW	DW	DW	DW					6 (MIN)*****
RESUME NORMAL OPERATION																	

SIGNAL	PERRINEVILLE ROAD (RT. 625)						PROSPECT PLAINS ROAD (RT. 614)						PEDESTRIAN SIGNALS				SIGNAL TIMING
	N.B.			S.B.			W.B.			E.B.			30,31	36,37	26-29	32-35	
PHASE	12,13,14	15,16,17,22	18,19,20	21,22,23,24	6,7,8	9,10,11	1,2,3	4,5	30,31	36,37	26-29	32-35					6 (MIN)**
4	← R	R	← R	R	G	G	G	G	DW	DW	W*	W*					
UPON ACTUATION																	
PED. CLEAR	← R	R	← R	R	G	G	G	G	DW	DW	FDW	FDW					18***
CHANGE	← R	R	← R	R	G	Y	Y	Y	DW	DW	DW	DW					5
CLEARANCE	← R	R	← R	R	G	G	R	R	DW	DW	DW	DW					2
EMERGENCY VEHICLE	← R	R	← R	R	← G/G	G	R	R	DW	DW	DW	DW					10 (MIN) AND HOLD UNTIL RELEASED****
CHANGE	← R	R	← R	R	← Y/Y	Y	R	R	DW	DW	DW	DW					5
CLEARANCE	← R	R	← R	R	← R	R	R	R	DW	DW	DW	DW					2
2	← R	G	← R	G	R	R	R	R	DW	DW	DW	DW					6 (MIN)*****
RESUME NORMAL OPERATION																	

EMERGENCY VEHICLE PREEMPTION

NOTES:

- * "DW" SHALL BE DISPLAYED IF PEDESTRIAN ACTUATION DOES NOT OCCUR.
 - ** MOVEMENT BEING PREEMPTED SHALL BE GUARANTEED A MINIMUM OF 6 SECONDS OF GREEN TIME.
 - *** IF PEDESTRIAN ACTUATION DOES NOT OCCUR, THIS PHASE SHALL BE SKIPPED.
- ACTUATION OF PREEMPTION SHALL NOT INTERRUPT ANY YELLOW CHANGE, ALL RED CLEARANCE OR FLASHING DON'T WALK PEDESTRIAN CLEARANCE TIMES. THE RESPECTIVE YELLOW CHANGE AND ALL RED CLEARANCE INTERVALS SHALL NOT BE SKIPPED PRIOR TO RESUMING NORMAL OPERATIONS.
- **** EMERGENCY VEHICLE SHALL BE GUARANTEED A MINIMUM OF 10 SECONDS GREEN TIME AND SHALL HOLD UNTIL RELEASED.
 - ***** PHASE 2 SHALL BE GUARANTEED A MINIMUM OF 6 SECONDS

TOWNSHIP OF MONROE
MIDDLESEX COUNTY, NEW JERSEY
MODIFICATIONS/UPGRADES TO PROSPECT PLAINS
ROAD AND PERRINEVILLE ROAD

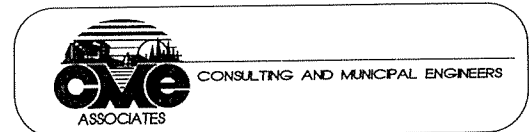

SIGNAL	PERRINEVILLE ROAD (RT. 625)				PROSPECT PLAINS ROAD (RT. 614)				PEDESTRIAN SIGNALS				SIGNAL TIMING	
	N.B.		S.B.		W.B.		E.B.		30,31	36,37	26-29	32-35		
	12,13,14	15,16,17,25	18,19,20	21,22,23,24	6,7,8	9,10,11	1,2,3	4,5						
PHASE 1	← G	R	← G	R	R	R	R	R	DW	DW	DW	DW	6 (MIN)**	
UPON ACTUATION														
CHANGE	← Y	R	← Y	R	R	R	R	R	DW	DW	DW	DW	3	
CLEARANCE	← R	R	← R	R	R	R	R	R	DW	DW	DW	DW	2	
EMERGENCY VEHICLE	← R	R	← R	R	R	R	R	← G/G	G	DW	DW	DW	DW	10 (MIN) AND HOLD UNTIL RELEASED****
CHANGE	← R	R	← R	R	R	R	R	← Y/Y	Y	DW	DW	DW	DW	5
CLEARANCE	← R	R	← R	R	R	R	R	R	R	DW	DW	DW	DW	2
2	← R	G	← R	G	R	R	R	R	DW	DW	DW	DW	6 (MIN)*****	
RESUME NORMAL OPERATION														

SIGNAL	PERRINEVILLE ROAD (RT. 625)				PROSPECT PLAINS ROAD (RT. 614)				PEDESTRIAN SIGNALS				SIGNAL TIMING	
	N.B.		S.B.		W.B.		E.B.		30,31	36,37	26-29	32-35		
	12,13,14	15,16,17,25	18,19,20	21,22,23,24	6,7,8	9,10,11	1,2,3	4,5						
PHASE 2	← R	G	← R	G	R	R	R	R	W*	W*	DW	DW	6 (MIN)**	
UPON ACTUATION														
PED. CLEAR	← R	G	← R	G	R	R	R	R	FDW	FDW	DW	DW	20***	
CHANGE	← R	Y	← R	Y	R	R	R	R	DW	DW	DW	DW	4	
CLEARANCE	← R	R	← R	R	R	R	R	R	DW	DW	DW	DW	3	
EMERGENCY VEHICLE	← R	R	← R	R	R	R	R	← G/G	G	DW	DW	DW	DW	10 (MIN) AND HOLD UNTIL RELEASED****
CHANGE	← R	R	← R	R	R	R	R	← Y/Y	Y	DW	DW	DW	DW	5
CLEARANCE	← R	R	← R	R	R	R	R	R	DW	DW	DW	DW	2	
2	← R	G	← R	G	R	R	R	R	DW	DW	DW	DW	6 (MIN)*****	
RESUME NORMAL OPERATION														

SIGNAL	PERRINEVILLE ROAD (RT. 625)				PROSPECT PLAINS ROAD (RT. 614)				PEDESTRIAN SIGNALS				SIGNAL TIMING
	N.B.		S.B.		W.B.		E.B.		30,31	36,37	26-29	32-35	
	12,13,14	15,16,17,25	18,19,20	21,22,23,24	6,7,8	9,10,11	1,2,3	4,5					
PHASE 3	← R	R	← R	R	← G/R	R	← G/R	R	DW	DW	DW	DW	6 (MIN)**
UPON ACTUATION													
CHARGE	← R	R	← R	R	← Y/R	R	← G/R	R	DW	DW	DW	DW	3
CLEARANCE	← R	R	← R	R	← R	R	← G/R	R	DW	DW	DW	DW	2
EMERGENCY VEHICLE	← R	R	← R	R	R	R	← G/G	G	DW	DW	DW	DW	10 (MIN) AND HOLD UNTIL RELEASED****
CHANGE	← R	R	← R	R	R	R	← Y/Y	Y	DW	DW	DW	DW	5
CLEARANCE	← R	R	← R	R	R	R	R	R	DW	DW	DW	DW	2
2	← R	G	← R	G	R	R	R	R	DW	DW	DW	DW	6 (MIN)*****
RESUME NORMAL OPERATION													

SIGNAL	PERRINEVILLE ROAD (RT. 625)				PROSPECT PLAINS ROAD (RT. 614)				PEDESTRIAN SIGNALS				SIGNAL TIMING
	N.B.		S.B.		W.B.		E.B.		30,31	36,37	26-29	32-35	
	12,13,14	15,16,17,25	18,19,20	21,22,23,24	6,7,8	9,10,11	1,2,3	4,5					
PHASE 4	← R	R	← R	R	G	G	G	G	DW	DW	W*	W*	6 (MIN)**
UPON ACTUATION													
PED. CLEAR	← R	R	← R	R	G	G	G	G	DW	DW	FDW	FDW	18***
CHANGE	← R	R	← R	R	Y	Y	G	G	DW	DW	DW	DW	5
CLEARANCE	← R	R	← R	R	R	R	G	G	DW	DW	DW	DW	2
EMERGENCY VEHICLE	← R	R	← R	R	R	R	← G/G	G	DW	DW	DW	DW	10 (MIN) AND HOLD UNTIL RELEASED****
CHANGE	← R	R	← R	R	R	R	← Y/Y	Y	DW	DW	DW	DW	5
CLEARANCE	← R	R	← R	R	R	R	R	R	DW	DW	DW	DW	2
2	← R	G	← R	G	R	R	R	R	DW	DW	DW	DW	6 (MIN)*****
RESUME NORMAL OPERATION													

EMERGENCY VEHICLE PREEMPTION

NOTES:

- * "DW" SHALL BE DISPLAYED IF PEDESTRIAN ACTUATION DOES NOT OCCUR.
 - ** MOVEMENT BEING PREEMPTED SHALL BE GUARANTEED A MINIMUM OF 6 SECONDS OF GREEN TIME.
 - *** IF PEDESTRIAN ACTUATION DOES NOT OCCUR, THIS PHASE SHALL BE SKIPPED.
- ACTUATION OF PREEMPTION SHALL NOT INTERRUPT ANY YELLOW CHANGE, ALL RED CLEARANCE OR FLASHING DON'T WALK PEDESTRIAN CLEARANCE TIMES. THE RESPECTIVE YELLOW CHANGE AND ALL RED CLEARANCE INTERVALS SHALL NOT BE SKIPPED PRIOR TO RESUMING NORMAL OPERATIONS.
- **** EMERGENCY VEHICLE SHALL BE GUARANTEED A MINIMUM OF 10 SECONDS GREEN TIME AND SHALL HOLD UNTIL RELEASED.
 - ***** PHASE 2 SHALL BE GUARANTEED A MINIMUM OF 6 SECONDS GREEN TIME.

TOWNSHIP OF MONROE
MIDDLESEX COUNTY, NEW JERSEY
MODIFICATIONS/UPGRADES TO PROSPECT PLAINS
ROAD AND PERRINEVILLE ROAD

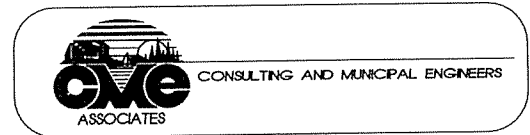

SHEET 5 OF 5, MARCH 2016
CME FILE NO.: PCT00091.01; COUNTY CODE NO.: MON010



Township of Monroe

County of Middlesex

PATRICIA REID
Township Clerk

Municipal Complex
1 Municipal Plaza
Monroe Township, NJ
08831-1900
Phone (732) 656-4573
Fax (732) 521-3190

Affidavit of Publication

I, Patricia Reid, Township Clerk, of the Township of Monroe, County of Middlesex, State of New Jersey, do hereby certify that the attached legal notice is a true copy of such notice, which was published in the Home News Tribune, the official newspapers of Monroe Township and newspaper of general circulation in the County of Middlesex on May 8, 2020.

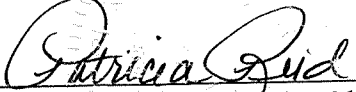

Patricia Reid, Township Clerk

Ad Number: 0004182521

Run Dates: 05/08/2020

MONROE TOWNSHIP, MIDDLESEX COUNTY NOTICE OF FINAL ADOPTION

Notice is hereby given that the following entitled Ordinance was introduced and passed on First Reading at the regular meeting of the Monroe Township Council held on April 6, 2020. Furthermore, this Ordinance was adopted after a Public Hearing was held at the May 4, 2020 regular meeting of the Monroe Township Council which was held telephonically, and was thereafter approved and signed by the Mayor on May 5, 2020.

ORDINANCE NO. O-4-2020-006

"ORDINANCE OF THE MONROE TOWNSHIP COUNCIL
AUTHORIZING THE ACCEPTANCE OF A TRAFFIC CONTROL SIGNAL
LOCATED AT THE INTERSECTION OF PROSPECT PLAINS ROAD (CR
614) AND PERRINEVILLE ROAD (CR 625) IN THE TOWNSHIP OF
MONROE, COUNTY OF MIDDLESEX, STATE OF NEW JERSEY"

PATRICIA REID, R.M.C.
Monroe Township Municipal Clerk

(\$18.92)

0004182521-01



Township of Monroe

County of Middlesex

PATRICIA REID
Township Clerk

Municipal Complex
1 Municipal Plaza
Monroe Township, NJ
08831-1900
Phone (732) 656-4573
Fax (732) 521-3190

Affidavit of Publication

I, Patricia Reid, Township Clerk, of the Township of Monroe, County of Middlesex, State of New Jersey, do hereby certify that the attached legal notice is a true copy of such notice, which was published in the Home News Tribune, the official newspapers of Monroe Township and newspaper of general circulation in the County of Middlesex on April 10, 2020.



Patricia Reid, Township Clerk

Ad Number: 0004144528

Run Dates: 04/10/2020

MONROE TOWNSHIP NOTICE OF PENDING ORDINANCE

ORDINANCE NO.: O-4-2020-006
NOTICE IS HEREBY GIVEN THAT AN ORDINANCE ENTITLED:
"ORDINANCE OF THE MONROE TOWNSHIP COUNCIL AUTHORIZING
THE ACCEPTANCE OF A TRAFFIC CONTROL SIGNAL LOCATED AT
THE INTERSECTION OF PROSPECT PLAINS ROAD (CR 614) AND PER-
RINEVILLE ROAD (CR 625) IN THE TOWNSHIP OF MONROE, COUNTY
OF MIDDLESEX, STATE OF NEW JERSEY", has been introduced and
passed on first reading at the regular meeting of the Monroe
Township Council held telephonically on April 6, 2020 and will be
further considered for final passage after a Public Hearing during
the council meeting to be held on May 4, 2020 at 6:30 p.m. in the
Monroe Twp. Municipal Building, One Municipal Plaza, Monroe
Twp., N.J. 08831 or held telephonically. Due to the current circum-
stances this has yet to be determined. At said time and place, all
persons will be granted the opportunity to be heard concerning
this Ordinance prior to its consideration for adoption by Council.

The purpose of this Ordinance is to accept the traffic control signal
located in the Township of Monroe at the intersection of Prospect
Plains Road (CR614) and Perrineville Road (CR625). The Traffic Con-
trol Signal shall be operated in conformance with the As Built Traf-
fic Signal Plan and Traffic Signal Timing Directive.

The proposed Ordinance in its entirety can be viewed on the
Township website, www.monroetwp.com and is on file in the Mu-
nicipal Clerk's Office. Copies may be obtained without charge be-
tween the hours of 8:30am and 4:30pm. Monday through Friday.

Patricia Reid, Municipal Clerk
(\$28.38)

0004144528-01